

BUBBLE GROWTH IN FLOWING LIQUIDS

R. A. M. AL-HAYES* and R. H. S. WINTERTON

Mechanical Engineering Department, Birmingham University,
P.O. Box 363, Birmingham B15 2TT, U.K.

(Received 24 April 1980 and in revised form 4 July 1980)

Abstract—Experimental results have been obtained for mass transfer to air bubbles adhering to the inside wall of a tube with supersaturated liquid flowing past. The liquids used were water, water with the addition of surface active agents, and ethylene glycol. Reasonable agreement with an analysis based on penetration theory was found.

NOMENCLATURE

A ,	surface area of bubble;
c ,	concentration of dissolved gas, mass/volume;
d ,	diameter of bubble;
d_e ,	diameter of equivalent sphere;
d_0 ,	initial bubble diameter;
D ,	molecular diffusivity;
h ,	half distance bubble projects from wall, equation (3);
k ,	liquid mass transfer coefficient;
l ,	length of bubble attached to wall, equation (4);
m ,	power in equation (5);
n ,	power in equation (5);
r ,	bubble radius;
r_0 ,	initial bubble radius;
Re_0 ,	initial bubble Reynolds number, interpreted for calculations as lu/v ;
Sc ,	Schmidt number, ν/D ;
t ,	time;
u ,	relative velocity of liquid flowing past bubble, velocity at a distance h from the wall;
V, V_0 ,	bubble volume, initial bubble volume;
δ ,	film thickness for diffusion;
θ ,	contact angle;
ν ,	kinematic viscosity;
ρ ,	density of gas.

INTRODUCTION

THE GROWTH of gas bubbles adhering to a wall with liquid flowing past does not appear to have been systematically studied, in spite of its potential importance in many fields. The results to be described in this paper are part of a program of work on the mass transfer processes which includes the question of the size of the bubbles when they detach into the flow.

It is widely accepted now that bubbles growing from dissolved gas that are then swept off solid surfaces into the flow are the main source of cavitation nuclei in

flowing systems [1]. Cavitation modelling experiments have been successfully interpreted in this way [2]. Also all the main trends evident in flowing liquid metal superheat experiments have been explained on the assumption of nucleation by gas bubbles that have come out of solution elsewhere in the system [3].

This paper describes the growth of air bubbles in water, water with surfactants, and ethylene glycol, on various surfaces exhibiting different contact angles. A companion paper describes the bubble diameter on detachment results [4].

Previous work on the growth of gas bubbles with liquid flowing past has been largely confined to freely rising bubbles. An early theoretical investigation was that of Boussinesq [5] who applied potential flow theory to the equivalent heat transfer problem. Interpreted as a mass transfer result this gives the liquid side mass transfer coefficient as

$$k = (4/\pi)^{1/2} (Du/d)^{1/2} \quad (1)$$

where D is the molecular diffusivity, u the relative velocity of bubble and liquid and d the bubble diameter.

Higbie [6] obtained the same result using penetration theory. Starting with the standard result that the average liquid mass-transfer coefficient for a sphere immersed in a liquid for a time t is $(4D/\pi t)^{1/2}$, he interpreted the time of exposure t for a bubble with liquid flowing past at a velocity u as d/u .

A number of measurements on freely rising bubbles have shown reasonable agreement either with equation (1) or with a slightly modified form of it. For example Calderbank *et al.* [7] made measurements on large, 5–40 mm equivalent spherical diameter, bubbles of carbon dioxide rising in distilled water, and interpreted d in equation (1) as the equivalent diameter. Johnson *et al.* [8] using similar sized bubbles of various gases recommended replacing d in the equation by $0.45 + 0.2d_e$ (cm units). The form of this comes from an empirical relation for the height of non-spherical bubbles, but the numerical values were chosen to agree with the experimental results. Griffith [9] found agreement with a version of the equation that had been modified to take into account the effects

* Present address: State Organization for Oil Projects, Baghdad, Iraq.

of static diffusion which become important for small bubbles.

Work on bubbles growing in contact with a solid surface appears to be confined to static liquids. Manley [10] observed the solution of bubbles in water trapped under a Perspex plate. The measurements were in reasonable agreement with the theory of Epstein and Plesset [11], but there was some evidence of reduced mass transfer at small bubble diameters which was attributed to a skin of organic impurity. Forster [12] presented a theoretical investigation into the effect the presence of a wall has on the growth of vapour bubbles in stagnant boiling. The interesting experimental observation that contact angle has no effect on the growth rate of carbon dioxide bubbles in water was made by Buehl and Westwater [13].

The effect of surface active agents on the rate of mass transfer seems to be variable. In order to achieve a reduction of 20% in mass-transfer surfactant concentrations in the hundreds or thousands of parts per million are usually required [14, 15]. However, a 20% reduction can result from as little as 1 ppm of *n*-octanol in water [16].

THEORY

To obtain our equation for the bubble volume as a function of time we adopt a simplified form of the penetration theory. It is a standard result of diffusion theory that a dissolved substance can diffuse a distance δ in a time t given approximately by $D = \delta^2/t$. If for the case of a bubble attached to a wall with liquid flowing past we assume that we can calculate the time of exposure to fresh liquid from some appropriate velocity u and linear dimension of the bubble d , then the film thickness is given by $\delta = (Dd/u)^{1/2}$.

The rate of mass transfer across this film for a bubble of surface area A is

$$AD\Delta c/\delta = A\Delta c(Du/2r)^{1/2}$$

i.e. as would be given by the Boussinesq equation apart from the factor of $(4/\pi)^{1/2} = 1.13$. Δc is the difference in concentration between the surface of the bubble and the bulk liquid, r is the bubble radius.

This rate of mass transfer equals the rate of increase of volume of the bubble multiplied by its density, ρ , i.e.

$$A dr\rho = A\Delta c(Du/2r)^{1/2} dt$$

or

$$r^{1/2} dr = (Du/2)^{1/2} (\Delta c/\rho) dt.$$

If we assume that u can be regarded as constant, which in the case of a bubble projecting into a turbulent flow is not unreasonable provided the range of values of r is not too great, then the equation can be integrated from an initial radius r_0 over a time interval t to give

$$(r/r_0)^{3/2} = 1 + (3\Delta c t/2\rho)(Du/2)^{1/2} r_0^{-3/2}$$

or in terms of final and initial volumes

$$V/V_0 = 1 + (3\Delta c t/\rho)(Du/2)^{1/2} r_0^{-3/2} + (9Du/8r_0^3)(\Delta c t/\rho)^2.$$

Introducing the initial bubble Reynolds number, $Re_0 = d_0 u/\nu$, and the Schmidt number, $Sc = \nu/D$, the equation becomes

$$V/V_0 = 1 + 6(Dt/d_0^2)(Re_0 Sc)^{1/2} (\Delta c/\rho) + 9(Dt/d_0^2)^2 Re_0 Sc (\Delta c/\rho)^2. \quad (2)$$

How u and d in the bubble Reynolds number are calculated is discussed later.

APPARATUS

The apparatus is shown in Fig. 1. The test section is simply a cylindrical tube of glass, Perspex, or glass treated with water repellent, fitted either in position AB or in CD, depending on the flow direction desired. Liquid at atmospheric pressure is drawn from the left hand reservoir through the test section, through the pump (8) and is discharged into the right hand reservoir. By partly closing the appropriate valve upstream of the test section the pressure in the test section falls low enough for dissolved gas to come out of solution and gas bubbles on the wall of the pipe start to grow and can be observed through the transparent walls. Obtaining a low pressure in the test section is assisted by having it some 1.5 m above the level of the free liquid surface in the reservoir.

Since there is considerable free surface in the circuit exposed to the atmosphere the dissolved air content of the liquid is always close to saturation at atmospheric pressure throughout the system. Once the pressure in the test section is reduced to about half an atmosphere absolute large numbers of bubbles appear on the walls. The size of the reservoirs was calculated on the basis that they would not allow any air bubbles through. Large bubbles would be able to rise out against the slow downward liquid velocity in the right hand reservoir, and smaller ones would have time to dissolve. The liquid siphoned over into the left hand reservoir was in fact always free of bubbles.

The flow rate is measured at the orifice (9) by the manometer (10) over a liquid of specific gravity 1.88. The pressure in the test section is measured by a mercury manometer (not shown). In preliminary measurements difficulty was experienced with pressure pulses from the pump reaching the test section and causing the bubbles to vibrate. This was overcome by fitting a damper in the line (11). This consists of a cylindrical chamber about 120 mm diameter and 370 mm long mounted with its axis horizontal and about 80% full of liquid.

Diameters of the bubbles and of the area of contact between the bubble and the wall are measured using a travelling microscope with a moving cross wire. The microscope is fitted on an optical bench and can be moved parallel to the test section. For the rates of bubble growth involved in these measurements this technique was found the most convenient, and for measurement of the contact area it was found to be

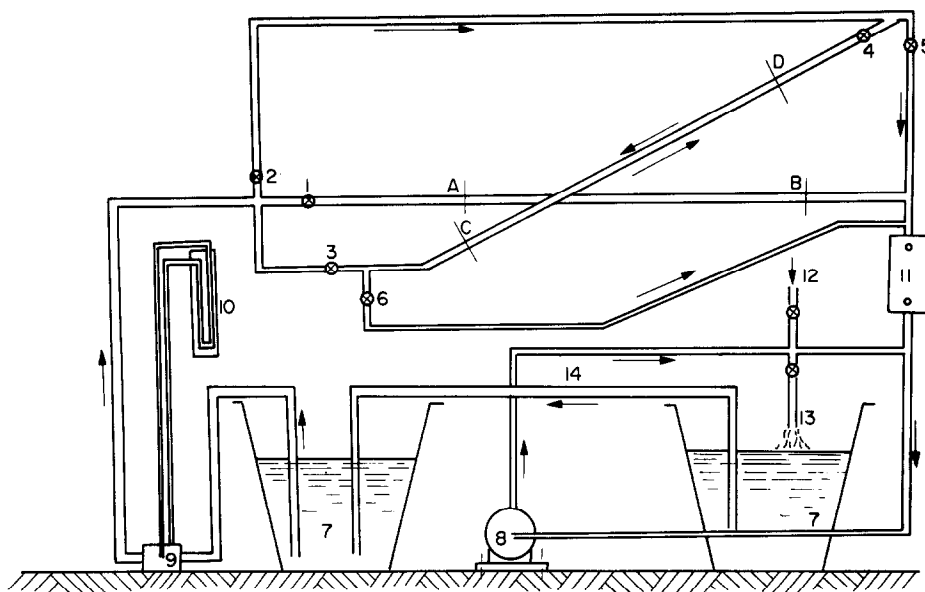

FIG. 1. Layout of the experimental rig. The test section goes in position AB or CD depending on the flow direction desired.

superior to photography, because frequently the contact area could not be clearly distinguished on the photographs.

The contact angle θ is calculated, from measurements on small bubbles whose spherical shape has not been distorted by the flow, using the formula

$$\sin \theta = \frac{\text{contact area diameter}}{\text{bubble diameter}}$$

The normal experimental procedure was to start at a low flow velocity, measuring bubble diameter as a function of time until the bubble broke away from the wall. Measurements were then repeated on another bubble at the same flow rate, until at least five sets of data had been obtained. Then the flow rate was increased. All the data at a given flow rate was then averaged.

The test liquids were water, water with surfactant and ethylene glycol. The main reason for studying the effect of surface active chemicals was to see if results obtained with pure liquids might not apply to a practical system because of trace contamination by surface active compounds. This is why we used commercial detergents rather than pure chemicals.

The surface active substances used were kindly supplied by Albright and Wilson Ltd. Four surface active agents were used to study their influence on the rate of mass transfer, and the bubble diameter on detachment. These surface active agents were:

(a) *EMDICOL ESB*: This agent is one of a range of three medium salts of sulphated lauryl alcohol. It contains (27.6%) sodiul lauryl sulphate, (0.8%) Free lauryl ether, (0.4%) sodium sulphate, (0.7%) sodium chloride, and (70.1%) water.

(b) *EMPILAN KA590*: This is an anionic agent, containing (90%) active matter.

(c) *NANSA KES 42*: This is a (42%) liquid detergent. It is based on a mixture of a straight chain sodium dodecyl benzene sulphate (26.0%), lauryl ether sulphate (9.0%), magnesium xylene sulphated (8.0%), the rest is water.

(d) *NANSA YS 94*: This is an isopropylamine salt of SO_3 -sulphated dodecyl benzene of the predominantly straight chain type. It is a viscous liquid, (10^4) centi-stokes at (20°C). It contains (94.0%) active matter, (1.0%) sulphate ion, the rest is water.

It proved impossible to use concentrations of these detergents much above 30 ppm because of foaming problems in the pumped circuit.

Two tube sizes were used, 19 and 23 mm i.d. For the upward and downward flow measurements the tubes were inclined at 40° to the horizontal.

The water repellent, used to give large contact angles, was 'Repelcote', a 2% solution of dimethyldichlorosilane in carbon tetrachloride.

MEASUREMENT OF PHYSICAL PROPERTIES

Nearly all of the properties of the test liquids that were required for the calculations were measured as part of the project.

Viscosity was measured using a capillary viscometer in the Chemical Engineering Department, density both using an accurate hydrometer and by weighing a known volume measured by a 1 cc pipette.

For the surface tension measurements we built an apparatus of the maximum bubble pressure type. Microscopic observation of the end of the capillary tube confirmed that the minimum bubble radius was

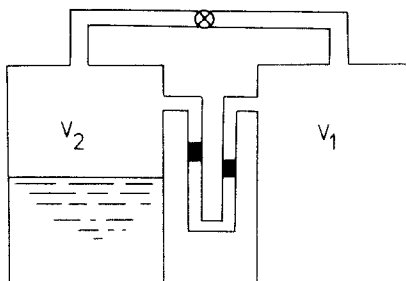

FIG. 2. Apparatus to measure the solubility of air in the various liquids.

that of the capillary, and the apparatus gave values for distilled water very close to the accepted ones.

To measure the solubility of air in the various liquids we designed and built an apparatus of the type used by Adeney [17]. The operation of this device depends on the change in pressure which occurs when a liquid is placed in contact with a closed volume of gas which it is capable of absorbing, as will be understood by reference to Fig. 2. The volume of gas V_2 , is connected through a manometer with a volume of gas V_1 , there being sufficient liquid in V_1 to ensure saturation of the gas with vapour, and the liquid under test is in contact with the gas in V_2 . When the tap is closed, any absorption of gas by the liquid from V_2 results in a decrease in pressure which is indicated on the manometer, and from this reading, the volume of gas absorbed can be calculated. The apparatus was constructed in glass and provided with a water jacket in which the temperature of the circulating water could be controlled by a thermostat. The absorption time is considerably reduced by using a magnetic stirrer. Initially the sample of liquid must be free of dissolved air, and this is ensured by connecting the vessel to a vacuum pump and stirring for at least an hour.

The diffusivities were not measured, the values used were $2.49 \times 10^{-5} \text{ cm}^2 \text{ s}^{-1}$ for water [18] and water with surfactant and $0.35 \times 10^{-5} \text{ cm}^2 \text{ s}^{-1}$ for ethylene glycol [19].

RESULTS

For water the measurements were made with fully developed turbulent flow in the test section and for ethylene glycol with laminar flow. The velocities used were limited at high flow rates by the very small numbers of bubbles that formed and by the very rapid way that they grew. The small number of bubbles at high flow velocities may have been due to the difficulty of maintaining a sufficiently low pressure in the test section, although for all measurements the test section pressure was substantially constant at around 60 kNm^{-2} , and did not rise much with increasing flow rates. The great majority of the bubbles appeared on the upper half of the test section wall, suggesting that the bubbles had nucleated on much smaller bubbles swept into the test section, that had risen under

buoyancy and become attached to the wall. These initial very small bubbles may well have originated from cavitation in the valves that were used to restrict the flow upstream of the test section. Frequently it was possible to hear a characteristic hissing noise close to the valves. For this reason it was not possible to make measurements on vertical test sections.

The local bubble Reynolds numbers for water ranged from about 40 to over 300. Fairly isolated bubbles were chosen for observation, ones that were in no danger of being touched by neighbouring bubbles and where bubble density in the immediate neighbourhood was $4\text{--}6 \text{ cm}^{-2}$ (with one exception, see later). In preliminary measurements on the treated glass surface it was found impossible to keep the bubble density down to this figure, and the growth rates were up to 50% lower than the ones reported in this paper. This problem was overcome by only treating a narrow ring of the test section with the water repellent, so that it became possible to make measurements on isolated bubbles.

The contact angle on the untreated glass surface was around 22° for the water and water with surfactant and 28° with ethylene glycol. The Perspex surface gave contact angles of around 30° with water and with the water containing surfactant, but with ethylene glycol

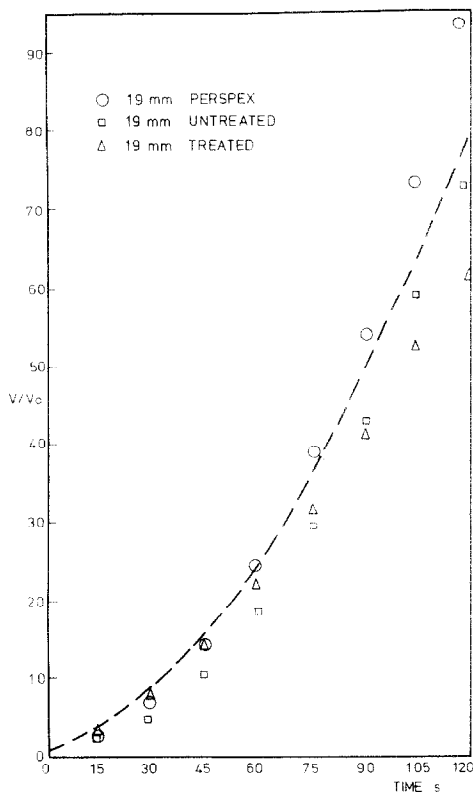

FIG. 3. Experimental results for horizontal flow of water through various 19 mm I.D. tubes. The theoretical bubble growth curve, in this and the following figures, is the prediction of equation (2) with $Re_0 = 1u/v$.

Table 1. Values to be inserted into the empirical equation (5), to reproduce the experimental bubble growth rate data for the various surfaces to good accuracy

Liquid	Tube diameter (mm)	Constant	n	m
Pure water	19	4.45	1.93	0.71
Pure water	23	10.3	1.74	0.39
Water with detergent	19	6.5	1.57	0.46

gave such low contact angles that the bubbles would not adhere to the surface and measurements could not be made. With the treated glass surface much higher contact angles were achieved, 90° for water and water with surfactant and 82° for ethylene glycol.

For pure water and ethylene glycol measurements were made for all possible combinations of tube size, nature of surface and flow direction. Since changing the flow direction did not have very much effect on the results, all the results for downward flow have been omitted from the figures. They were however, included in the data used to establish the empirical equations of Table 1. Preliminary experiments revealed that none of the surface active agents produced results that were dramatically different from those for pure water, so the detailed measurements were largely confined to 10 ppm of Nansa YS 94 in the 19 mm tube.

The results for dimensionless bubble volume in water as a function of time are shown in Figs. 3–8 inclusive. In each case the theoretical curve is based on equation (2), but with the Reynolds number calculated as follows. The velocity is calculated from the appropriate velocity profile at a position equal to half the distance the bubble projects from the wall, as shown in Fig. 9, that is at a distance of h from the wall given by

$$h = d(1 + \cos \theta)/4. \quad (3)$$

The diameter d in the Reynolds number is replaced by the length of the bubble at a distance h from the wall, that is by

$$l = d(0.75 + 0.5 \cos \theta - 0.25 \cos^2 \theta)^{1/2}. \quad (4)$$

Figure 10 shows typical data for the variation of

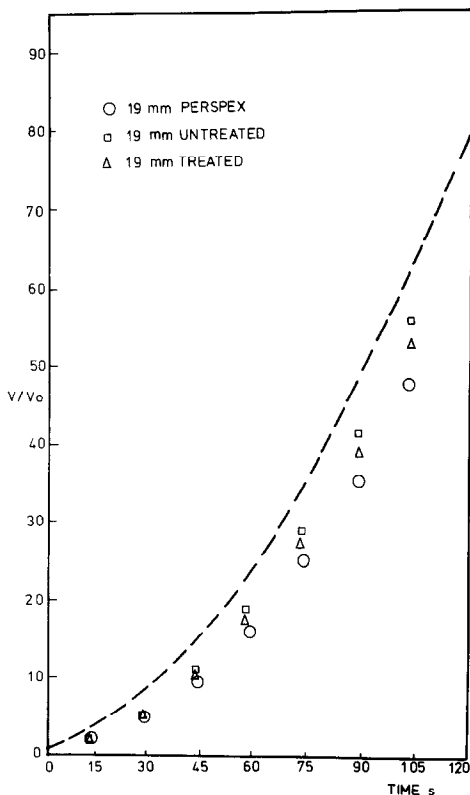

FIG. 4. Results for upward flow of water in inclined 19 mm tubes.

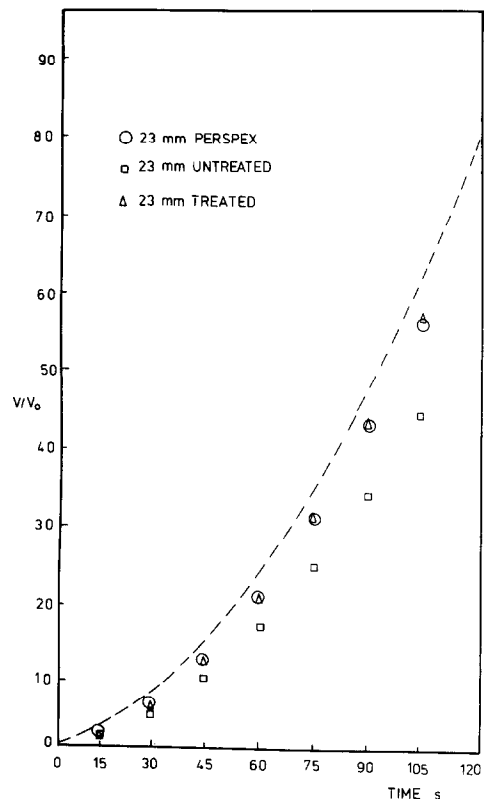

FIG. 5. Results for horizontal flow of water in 23 mm tubes.

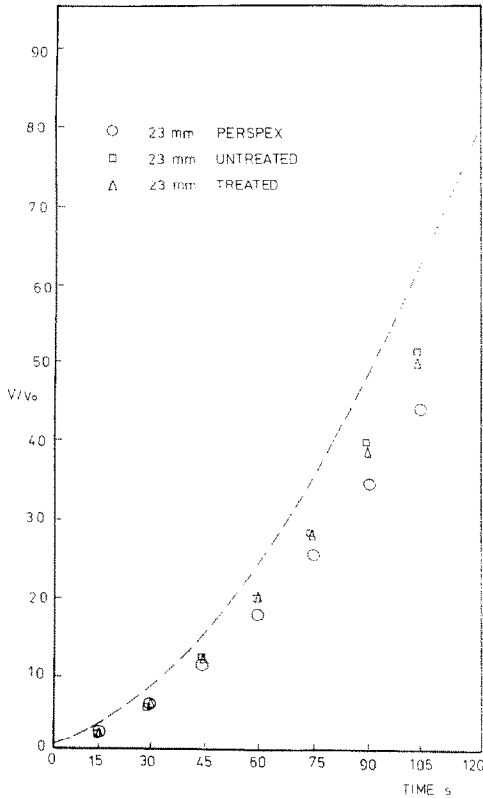

FIG. 6. Results for upward flow of water in inclined 23 mm tubes.

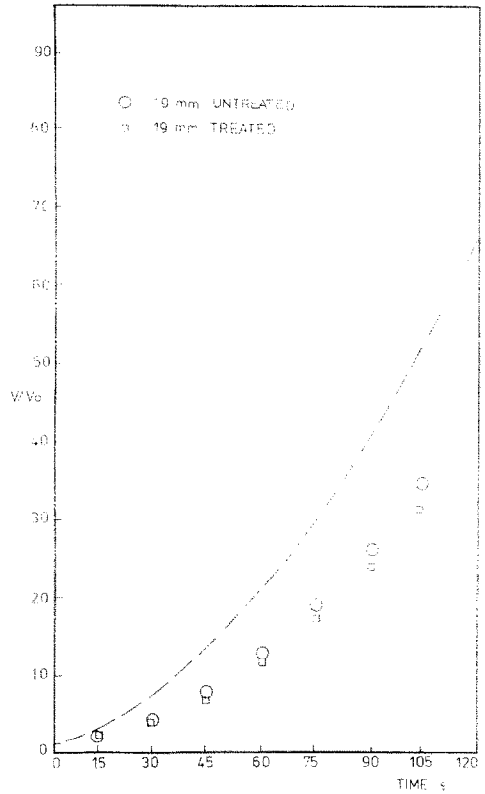

FIG. 8. Results for upward flow of water with surfactant.

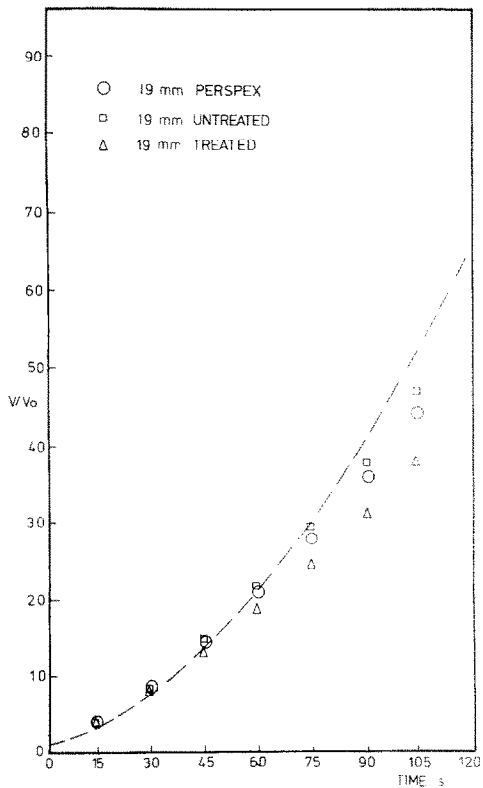

FIG. 7. Results for horizontal flow of water with 10 ppm surfactant (Nansa YS 94).

bubble growth rate with initial bubble Reynolds number.

It was found possible to summarise the experimental data using a small number of equations of the form

$$V/V_0 = 1 + \text{constant} (tD/d_0^2)^n Re_0^m \quad (5)$$

The values of the constants and the powers n and m are given in Table 1. These equations reproduce all of the experimental results with an accuracy of about $\pm 10\%$. Re_0 is calculated in the same way, that is using the velocity at a distance h from the wall and the linear dimension l .

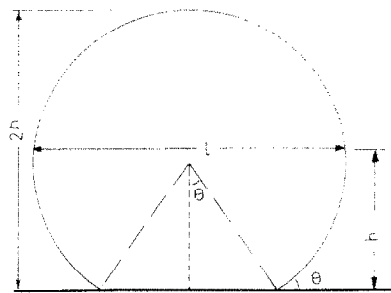

FIG. 9. For the purposes of calculation the bubble on the wall is assumed to be a truncated sphere. The bubble Reynolds number is calculated using the velocity at a distance h from the wall and the distance l .

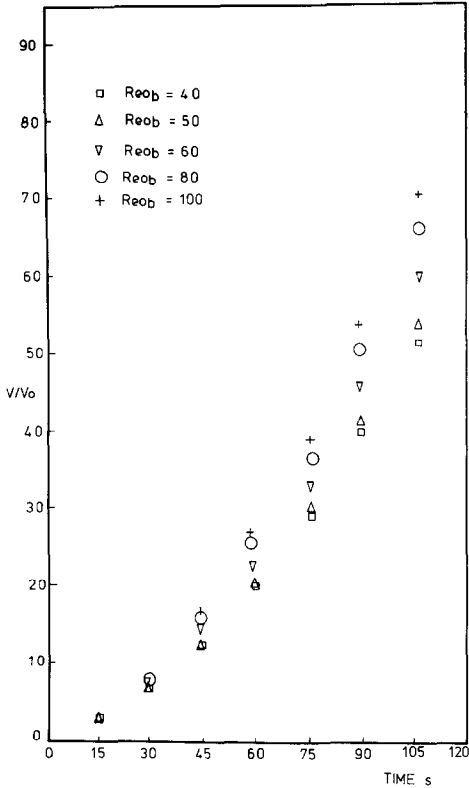

FIG. 10. Experimental results showing the influence of initial bubble Reynolds number on the bubble growth rate.

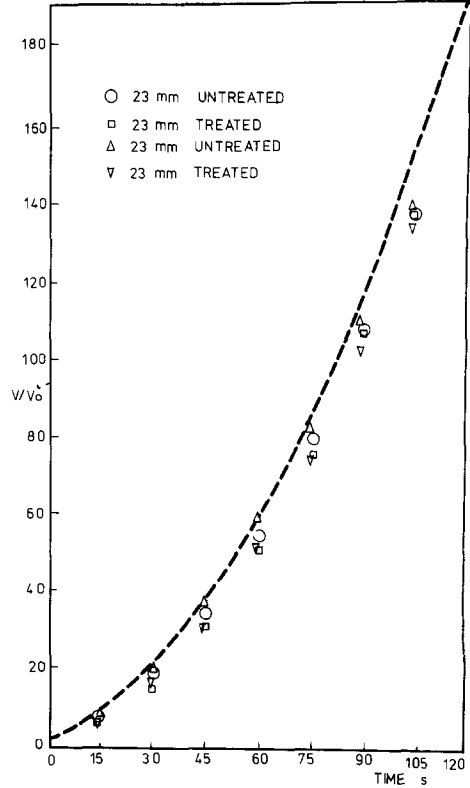

FIG. 12. Results for ethylene glycol in 23 mm tubes. The circles and squares represent horizontal flow, the triangles upward flow.

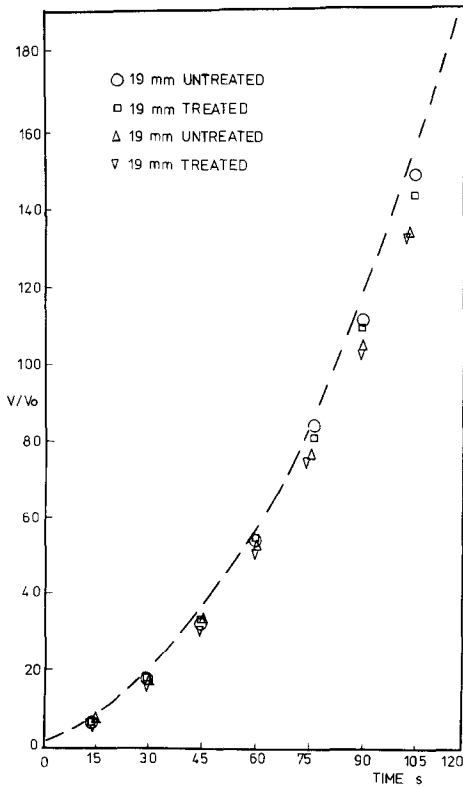

FIG. 11. Results for flow of ethylene glycol in 19 mm tubes. Experimental points for horizontal flow are indicated by circles and squares, and ones for inclined, upward flow by triangles.

The ethylene glycol results are shown in Figs. 11 and 12. Equation (2) is not valid for a laminar flow, so no theoretical prediction is given.

DISCUSSION

The experimental results for turbulent flow are in reasonable agreement with the theoretical predictions of equation (2), with the Reynolds number calculated as explained above. In fact all of the results are within +20% and -30% of the theoretical prediction, and the great majority within +0% and -20%. This is for V/V_0 values up to at least 50. In one case where the mass transfer rate was on the low side the explanation is probably that the bubbles on the surface were too close together, and neighbouring bubbles reduced the supply of fresh liquid available to the bubble under observation. This was in the 23 mm Perspex tube with water where the bubble density was higher at $6-8 \text{ cm}^{-2}$.

If more than a few percent of the surface is covered with bubbles the rate of mass transfer to an individual bubble will be significantly below the levels reported in this paper.

The addition of surfactant to the water resulted in significantly lower growth rates, but most of the reduction was due to the changed density, viscosity and solubility, that is the theoretical prediction of equation (2) is reduced, so there is little evidence of any

anomalous reduction in mass transfer due to surface skin effects.

The general trend of the ethylene glycol results is very similar to that of the other liquids. If the results are fitted to the empirical equation (5) then the exponent of the $(tD/d_0)^2$ term is 1.68, within the range obtained in Table 1. Since in a laminar flow the liquid velocity past the bubble increases rapidly as the bubble grows it is a little surprising that the exponent is not higher.

Although the equations given by Table 1 give the experimental data with about twice the accuracy of equation (2) there does not appear to be any good reason to prefer them. Equation (2) is a single equation covering all the cases and has some theoretical justification.

CONCLUSIONS

Mass transfer to bubbles adhering to a wall with liquid flowing past can be predicted using a theory similar to that successfully used for freely rising bubbles. For the surface active agents used there was little evidence that they produced a skin around the bubble that significantly impeded the mass transfer.

Acknowledgement—The work described in this paper was supported by a grant from the Science Research Council.

REFERENCES

1. T. Knapp, J. W. Daily and F. G. Hammit, *Cavitation*. McGraw-Hill, New York (1970).
2. R. Oshima, Theory of scale effects on cavitation inception on axially symmetric bodies, *J. Bas. Engng* **83**, 379–384 (1961).
3. R. H. S. Winterton, Liquid metal superheat in forced convection, *Int. J. Heat Mass Transfer* **18**, 205–212 (1975).
4. R. A. M. Al-Hayes and R. H. S. Winterton, Bubble diameter on detachment in flowing liquids, *Int. J. Heat Mass Transfer* **24**, 223–230 (1981).
5. J. Boussinesq, Calcul du pouvoir refroidissant des courants fluides, *J. Math. Pure Appl.* **11**, 285–317 (1905).
6. R. Higbie, Rate of absorption of a pure gas into a still liquid, *Am. Inst. Chem. Engng Trans.* **31**, 365–389 (1935).
7. P. H. Calderbank, D. S. C. Johnson and J. London, Mechanics and mass transfer of single bubbles in free rise, *Chem. Engng Sci.* **25**, 235–256 (1970).
8. A. I. Johnson, F. Besik and A. E. Hamielec, Mass transfer from a single rising bubble, *Can. J. Chem. Engng* **47**, 559 (1969).
9. R. M. Griffith, Mass transfer from drops and bubbles, *Chem. Engng Sci.* **12**, 198–213 (1960).
10. D. M. J. P. Manley, Change of size of air bubble in water containing a small dissolved air content, *Br. J. Appl. Phys.* **11**, 38–42 (1960).
11. P. Epstein and M. Plesset, On the stability of gas bubbles in liquid-gas solutions, *J. Chem. Phys.* **18**, 1505–1509 (1950).
12. K. E. Forster, Growth of vapour filled cavity near a heated surface, *Phys. Fluids* **4**, 448 (1961).
13. W. M. Bushel and J. W. Westwater, Bubble growth by dissolution: influence of contact angle, *A.I.Ch.E. JI* **12**, 571–576 (1966).
14. K. Koide, T. Hayashi, K. Sumino and S. Iwamoto, Mass transfer from single bubble in Newtonian liquid, *Chem. Engng Sci.* **31**, 963–967 (1976).
15. J. G. Vogtlander and F. W. Meijboom, A new method for measuring the transfer of oxygen in liquids, *Chem. Engng Sci.* **29**, 799–803 (1974).
16. D. R. Raymond and S. A. Zieminski, Mass transfer and drag coefficients of bubble rising in dilute aqueous solutions, *A.I. Ch. E. JI* **17**, 57–65 (1971).
17. W. E. Adeney, The determination of the rate of solution of atmospheric nitrogen and oxygen by water, *Phil. Mag.* **6**, 385 (1920).
18. *International Critical Tables*, Vol. 5, p. 62. McGraw-Hill, New York (1929).
19. J. H. Leonard and G. Houghton, Mass transfer and velocity of rise phenomena for single bubbles, *Chem. Engng Sci.* **18**, 133 (1963).

CROISSANCE DE BULLE DANS DES LIQUIDES EN ECOULEMENT

Résumé—On présente des résultats expérimentaux sur le transfert de masse à des bulles d'air qui adhèrent à la paroi interne d'un tube à l'intérieur duquel coule un liquide sursaturé. Les liquides utilisés sont l'eau, l'eau avec addition d'agents tensioactifs et l'éthylène-glycol. On trouve un accord assez satisfaisant avec une analyse basée sur la théorie de la pénétration.

BLASENWACHSTUM IN STRÖMENDEN FLÜSSIGKEITEN

Zusammenfassung — Für den Stoffübergang an Luftblasen, die an der Innenseite eines Rohres haften, das von übersättigter Flüssigkeit durchströmt wird, wurden experimentelle Ergebnisse erhalten.

Die verwendeten Flüssigkeiten waren Wasser, Wasser mit einem Zusatz oberflächenaktiver Substanzen und Äthylenglykol. Gute Übereinstimmung mit einer auf dem Penetrationsmodell beruhenden analytischen Berechnung wurde festgestellt.

РОСТ ПУЗЫРЬКОВ ПРИ ТЕЧЕНИИ ЖИДКОСТЕЙ

Аннотация — Получены экспериментальные данные по переносу массы к пузырькам воздуха на внутренней стенке трубы при течении пересыщенной жидкости. В качестве жидкостей использовались вода, вода с добавками поверхностноактивных веществ и этилен гликоль. Получено удовлетворительное совпадение с результатами аналитического исследования на основании теории проникновения.